

LINEA 100 P

(Model ADH1000F - ADHP550AU)

Heat Output	▪ 17.0kW ave Peak
Efficiency	▪ 70% peak [64% ave]
Coverage	▪ up to 250m ²
Emissions	▪ 1.2 grams/kg

Coupled with a sleek European design and manufacture, ADF brings the next level in quality and functionality with the launch of the Linea 100 P wood-burning fire.

Externally the Linea 100 P has a minimalistic, timeless shape. The spectacular large soot-free glass door ensures a beautiful and uninterrupted view of the flames and is easy to open with its removable handle. The clean lines of the firebox are constructed using high-strength 5mm quality steel, and is balanced on a contemporary pedestal base.

These fires aren't only eye-catching, they operate beautifully. Internally a unique automatic flue damper significantly reduces smoke ingress to the room on re-fuelling, and a high-density vermiculite lining system insulates the combustion chamber providing better heat reflection. In addition the simplicity in design of the air wash and primary air system belies how well these fires function.

Since the beginning of its operations in 1976, ADF has been at the forefront of stove design and technology. Focusing on quality and innovation, its R&D laboratory facilities were created in the 1980s and, in 2004, the ISO 9001 quality management system was adopted. Acquiring an ADF wood burning appliance, isn't simply insuring heating solution for your home: it is comfort, dependability, well-being and a work of art.



Clearances

Hearth depth inc 750mm in front. Thickness: Equal to 24mm Bellis Board or equivalent	Width	Depth	Thickness
Parallel No Shielding	1250	1500	24
Parallel with 25mm Skamol 1910mm [w] x 1700mm [d] wall to be attached directly to the wall	1250	1250	24
Parallel with 180° x 900 s/s Rear Flue Shield and Firebox Heat Shield	1250	1300	24

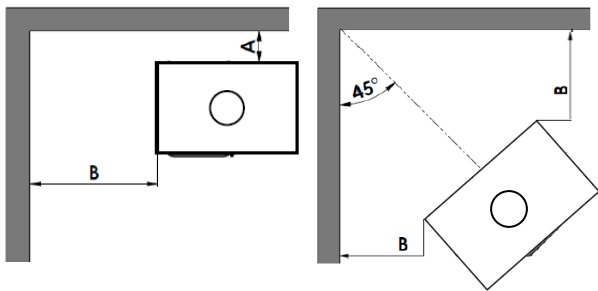

Flue Shield Configuration	Rear [A]	Side [B]	Front	Corner
Parallel No Shielding	300	525	750	525
Parallel with 25mm Skamol 1910mm [w] x 1700mm [d] wall to be attached directly to the wall	50	525	750	525
Parallel with 180° x 900 s/s Rear Flue Shield and Firebox Heat Shield	100	525	750	525

CLEARANCES BASED ON INSTALLATION HAWKWIND 200MM TRIPLE SKIN FLUE KIT

Dimensions

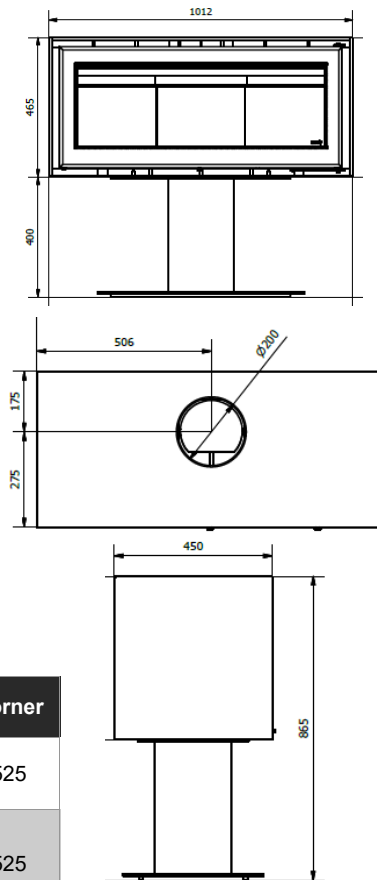

Features

STANDARD FEATURES

- Constructed using high-strength 5mm quality black steel
- Contemporary steel pedestal base
- Automatic flue damper system significantly reduces smoke ingress to the room on re-fuelling
- High density vermiculite lining system insulates the combustion chamber, providing better heat reflection
- Superior air wash system keeps the glass clean for unparalleled fire viewing
- Removable door handle, ensures a cool touch when stoking or refueling the fire
- Single air control for ease of operation
- Vertical smoke exit through the top
- Weight : 206kilos
- Maximum log width : 300mm
- Flue Spigot Size : 200mm
- Internal Firebox : 879[w] x 383[d] x 221-275[h]
- Viewing Area : 920[w] x 380[h]
- Warranty : Limited 5 years manufactures

OPTIONAL ACCESSORIES

- Heat Shield [enables a reduction in rear clearances]

Information supplied is to assist you in your choice of a suitable fire. It is not intended to be all the information required to install the fire and does not replace the installation manual which provided more detailed information. In the interest of product development ADF reserves the right to change specifications without prior notice.

All measurements are in millimetres unless otherwise stated.